

TITANWALL

Panel Connection

Details

CUT OUT PANEL AS REQUIRED TO
SUIT BEAM. SEE DETAIL E1/E2 FOR
PANEL ASSEMBLY AT
POST LOCATIONS

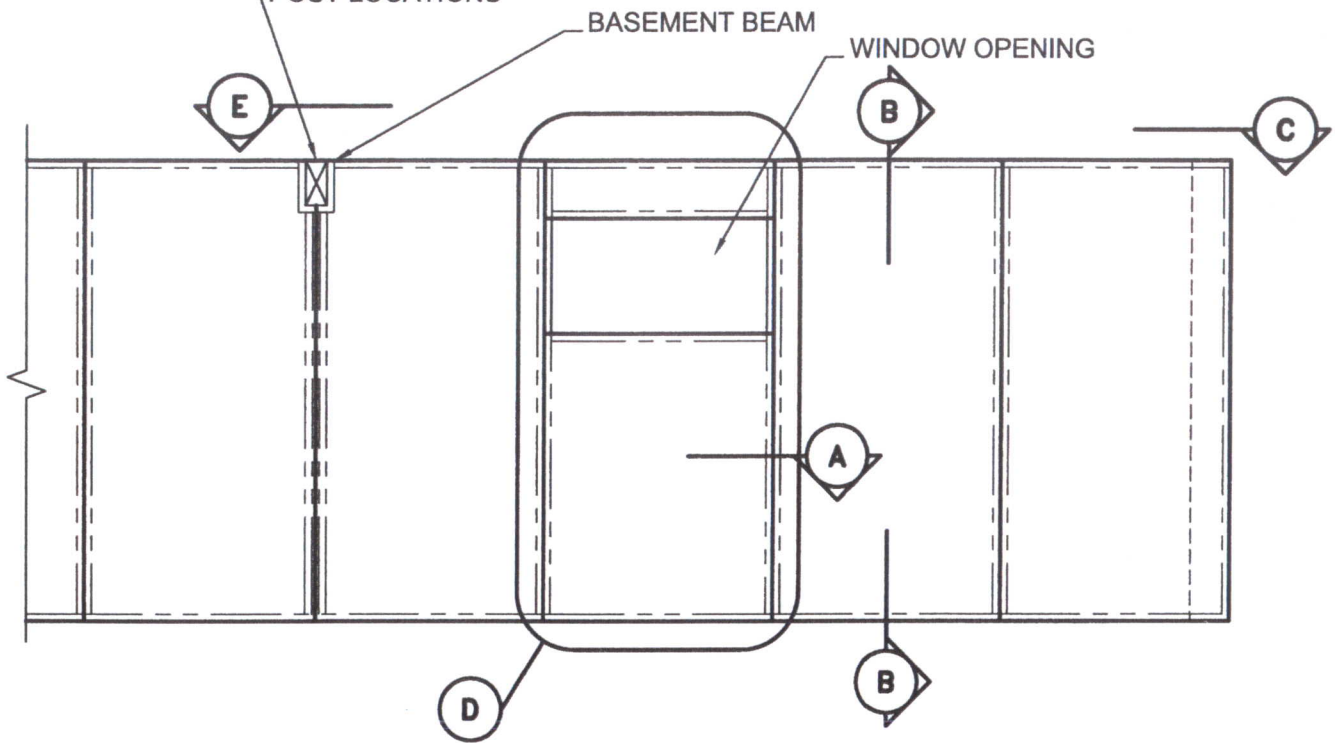

SAMPLE WALL ELEVATION

PFK DEVELOPMENTS

TITAN

TYPICAL WALL PANELS
PANELS

TW-01

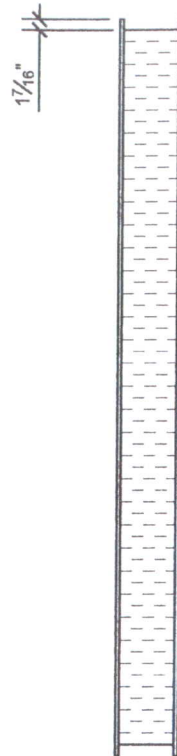
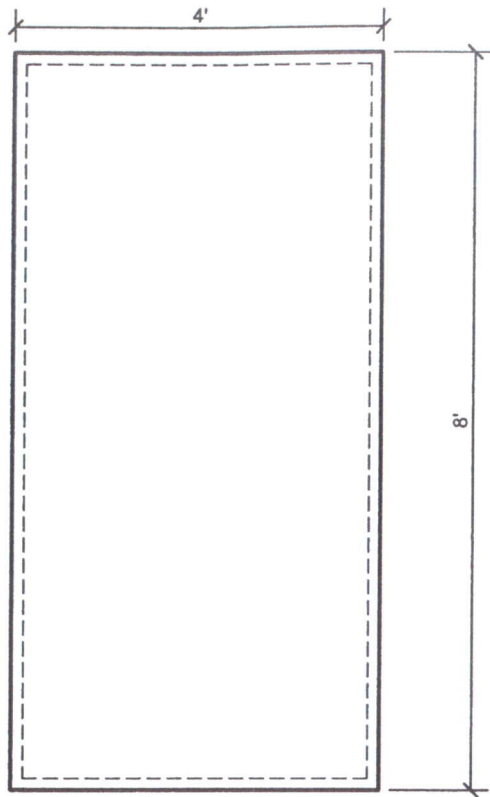

1/2" MAGBOARD
EPS CORE (7 1/4")
1/2" MAGBOARD

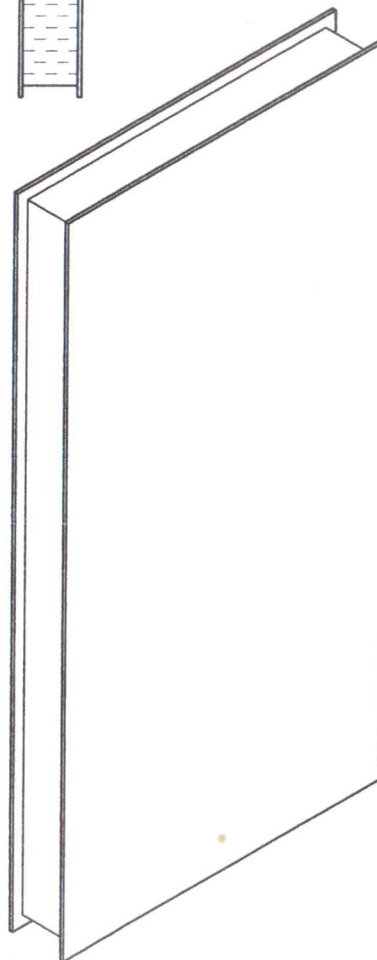
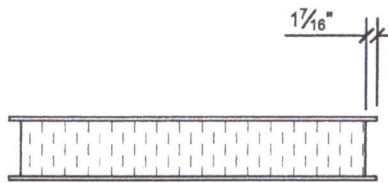

PFK DEVELOPMENTS

TITAN

TYPICAL PANEL

TW-02

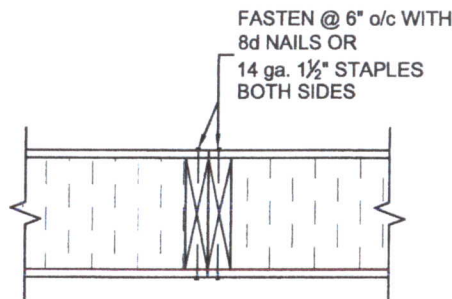
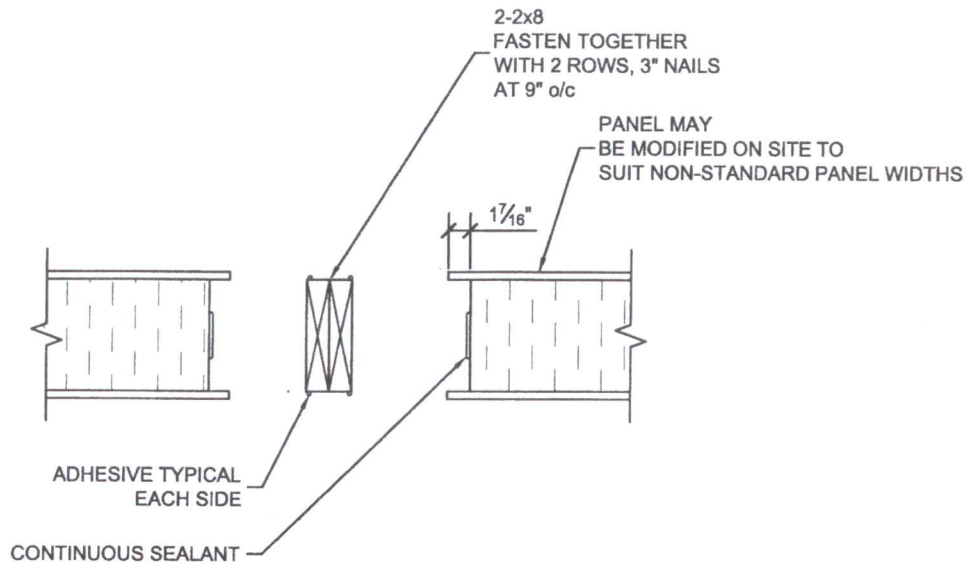

PFK DEVELOPMENTS

TITAN

TYPICAL SPLINE
CONNECTION DETAIL

TW-A

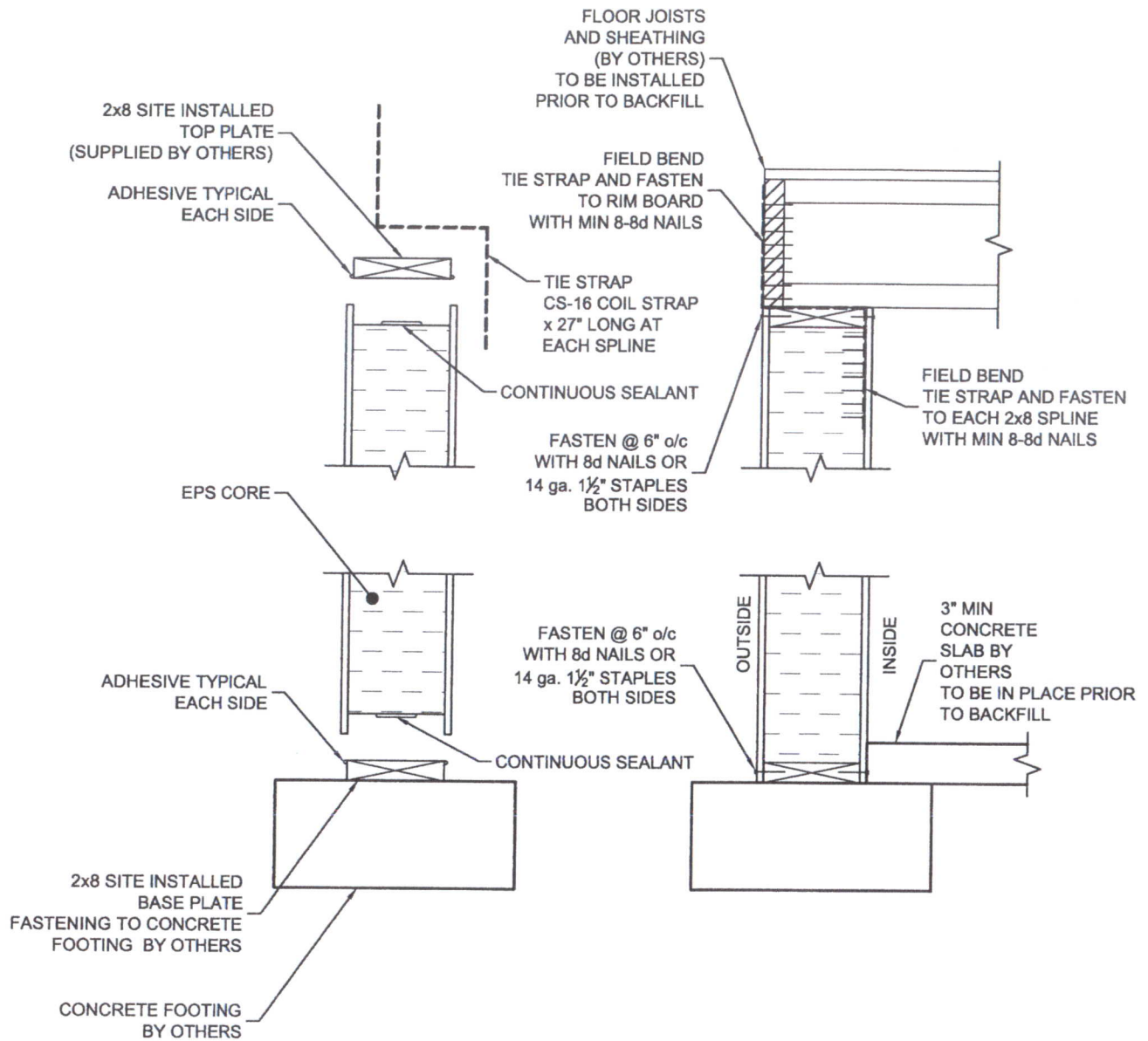

PFK DEVELOPMENTS

TITAN

PLATE CONNECTIONS

TW-B1

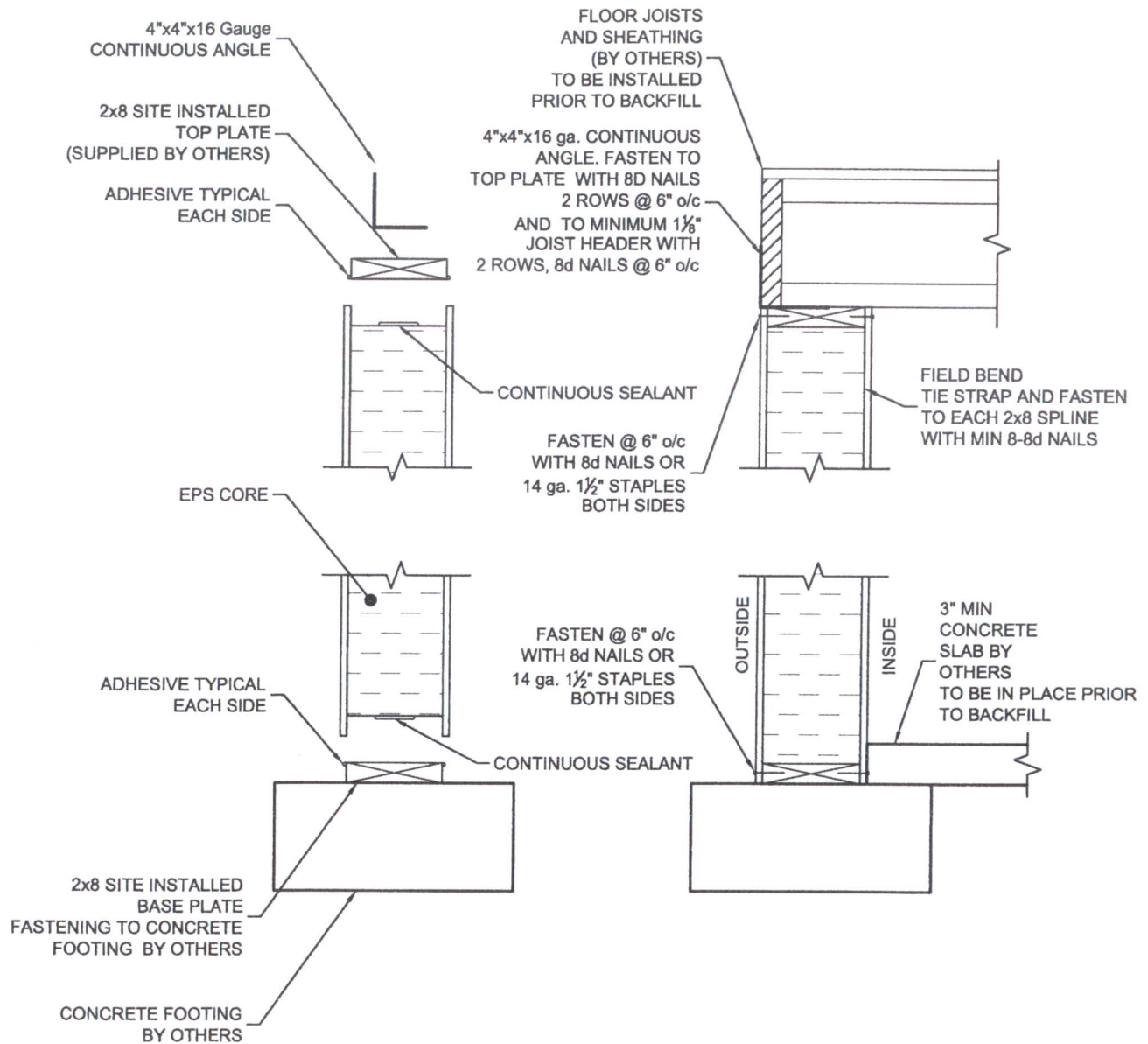

PFK DEVELOPMENTS

TITAN

PLATE CONNECTIONS

TW-B2

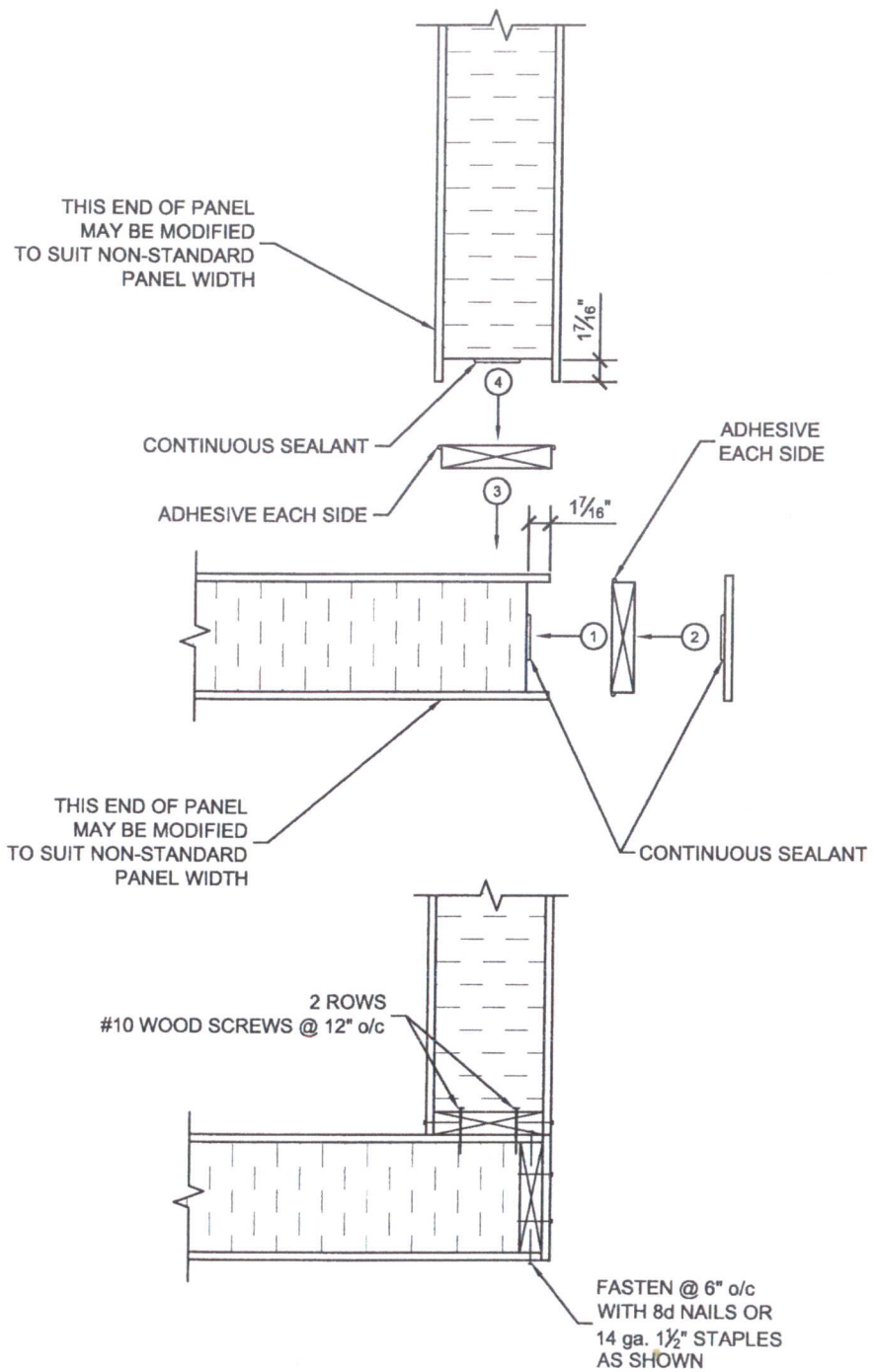

PFK DEVELOPMENTS

TITAN

CORNER PANEL
CONNECTION

TW-C

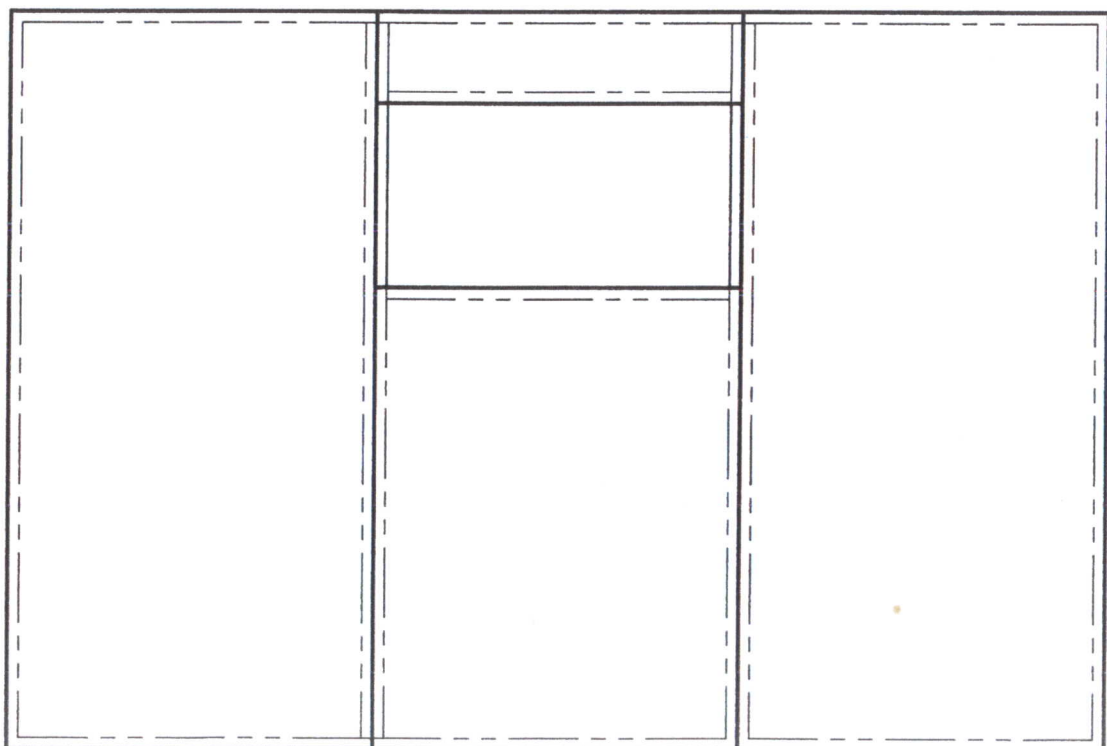
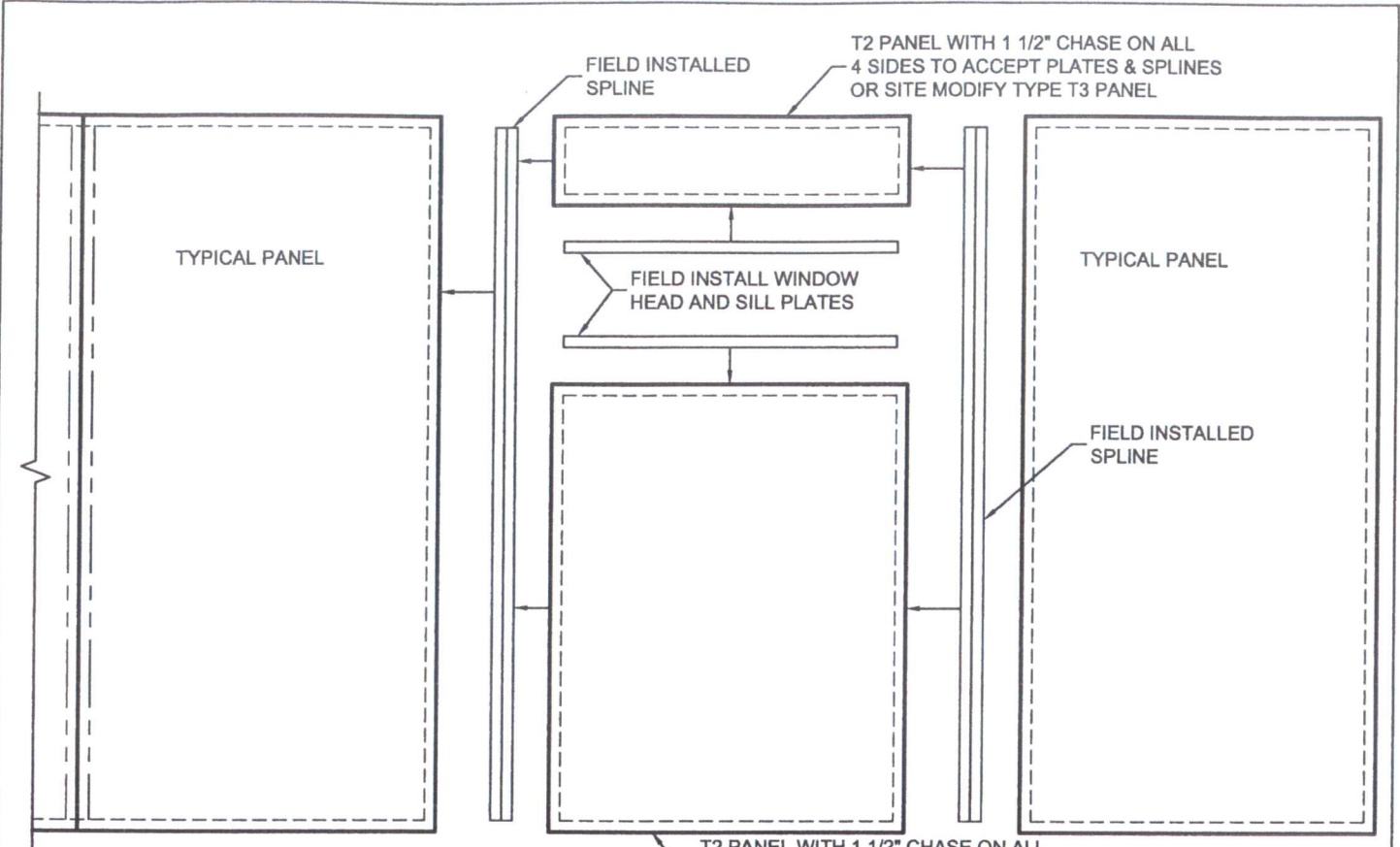

PFK DEVELOPMENTS

TITAN
 PANEL WINDOW ASSEMBLY
 TW-D

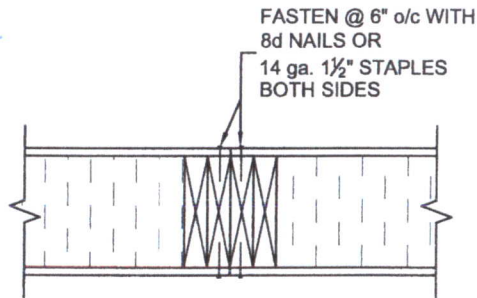
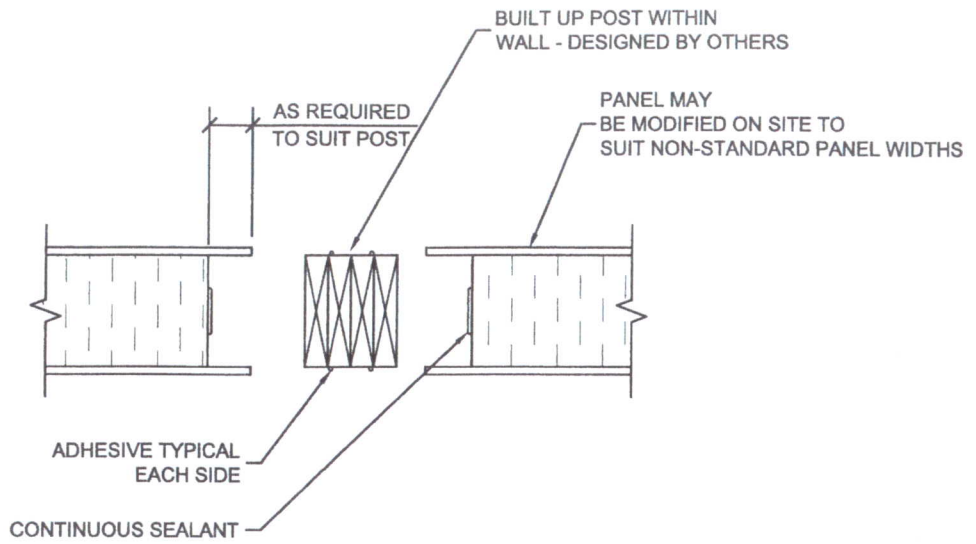

PFK DEVELOPMENTS

TITAN

BUILT UP POST
WITHIN WALL

TW-E1

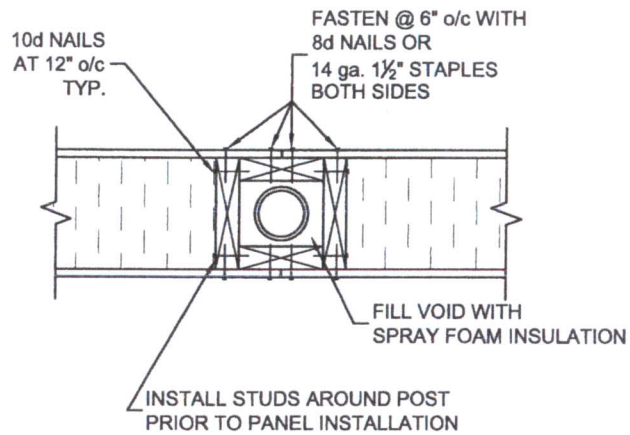
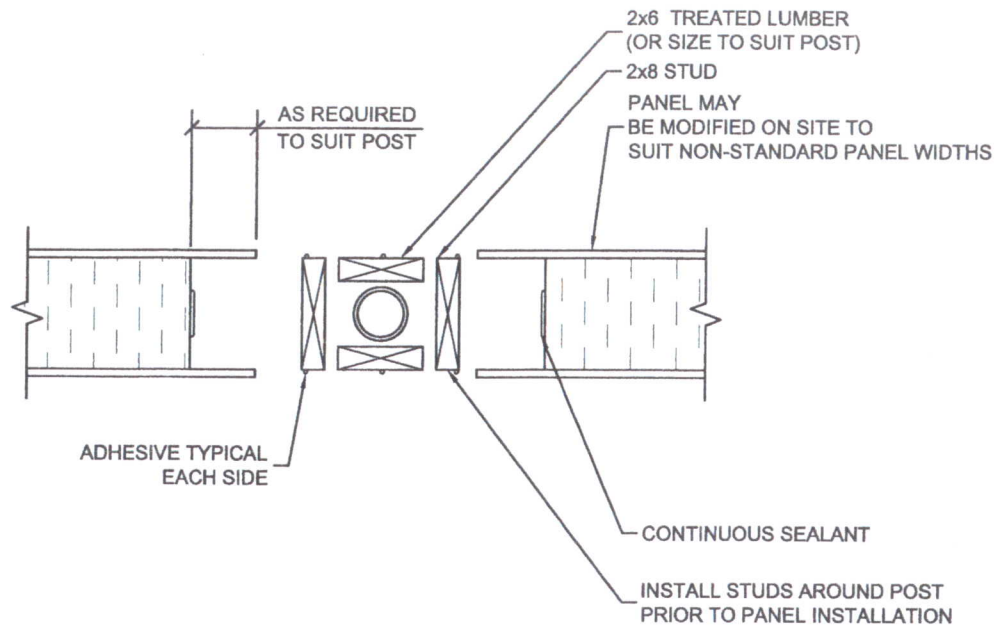

PFK DEVELOPMENTS

TITAN

STEEL POST WITHIN
WALL PANEL

TW-E2

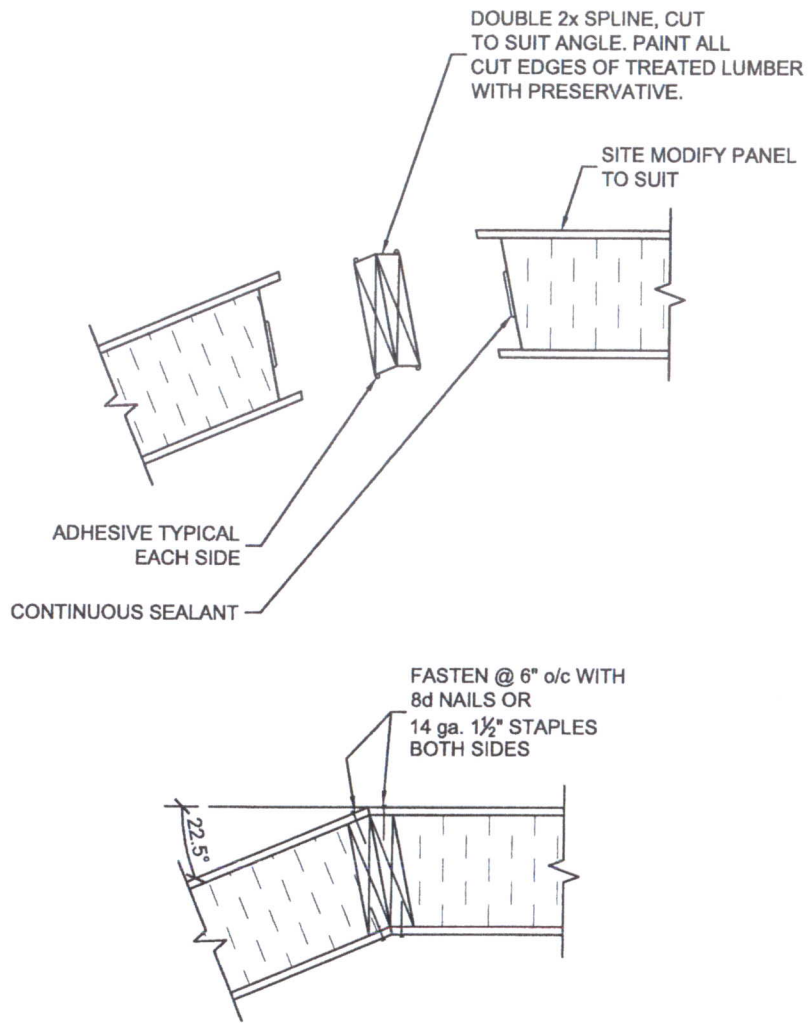

PFK DEVELOPMENTS

TITAN

22 1/2° MITRE CORNER
DETAIL

TW-F

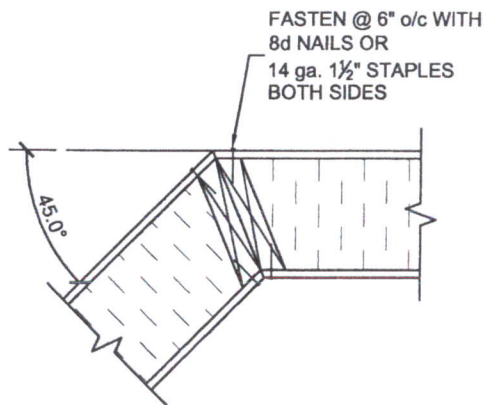
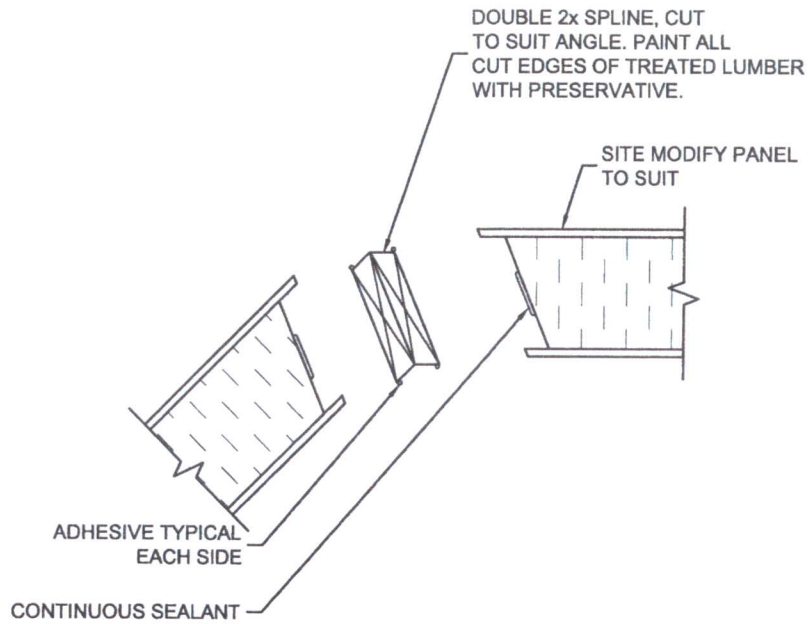

PFK DEVELOPMENTS

TITAN

45° MITRE CORNER
DETAIL

TW-G